

# Appendix B

---

## Sketches

### Chapter 4 > Tutorial 3

The following steps explain the procedure to create the sketch of the second feature created in Tutorial 3 of Chapter 4. The sketch in Figure 4-85 is shown in Figure B-1.

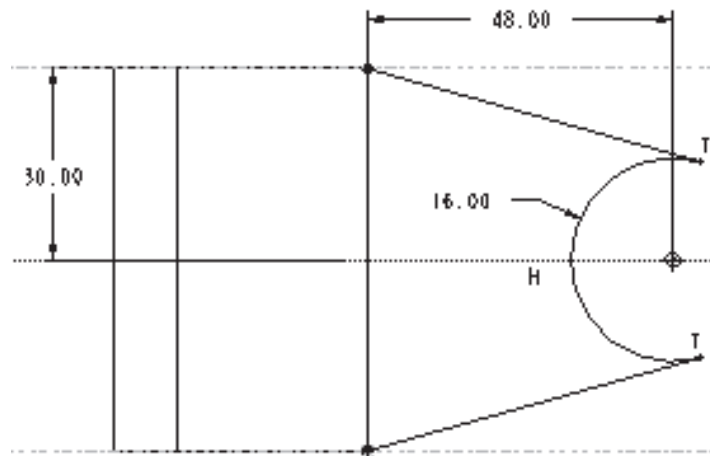

*Figure B-1 Sketch of the second feature*

### Creating the Sketch

1. Choose the black arrow on the right of the **Create lines.** button to display the flyout. From this flyout, choose the **Create centerlines.** button. Draw a center line such that it passes

approximately from the middle of the existing feature.

- Choose the black arrow on the right of the **Create centerlines.** button to display the flyout. From the flyout, choose the **Create lines.** button and draw an inclined line from the top right vertex as shown in Figure B-2. When you are prompted to align the highlighted entities, choose **Yes** from the **Confirm** dialog box. Similarly, draw the second inclined line from the bottom right vertex. Draw a line joining the top right vertex and the bottom right vertex as shown in Figure B-2.
- Choose the **Create an arc by 3 points or tangent to an entity at its endpoint.** button. Draw an arc by selecting the three points; the first point being the endpoint of the top inclined line, the second point the endpoint of the bottom inclined line, and the third point being at the left in the sketch. The arc is created as shown in Figure B-3.

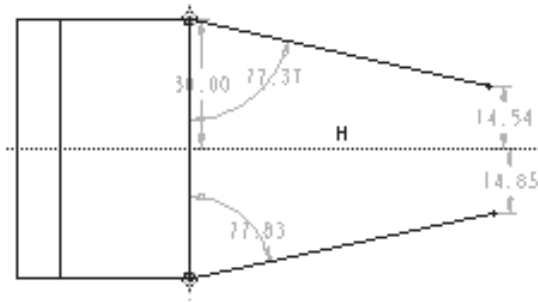

*Figure B-2 Lines drawn*

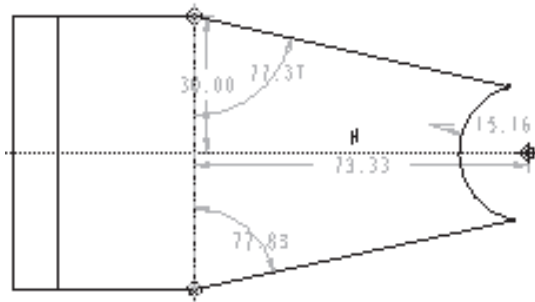

*Figure B-3 Sketch before applying constraints and dimensions*

### Applying Constraints

- Choose the **Impose sketcher constraints on the section.** button. The **Constraints** dialog box is displayed.
- Choose the **Create same points, points on entity, or collinear constraint** button and align the center point of the arc with the center line.
- Choose the **Make two entities tangent** button and select the top inclined line and the arc. Similarly, make the bottom inclined line tangent to the arc. The sketch after applying the constraints is shown in Figure B-4.

Note that the endpoints of the two inclined lines are aligned with the right edge of the base feature.

### Applying Dimensions

- Choose the **Create defining dimension.** button and select the center of the arc and the right edge of the base feature and place the dimension as shown in Figure B-5.

2. Select the top edge of the base feature and the center line and place the dimension using the middle mouse button as shown in Figure B-5.
3. Select the arc and place the dimension as shown in Figure B-5.

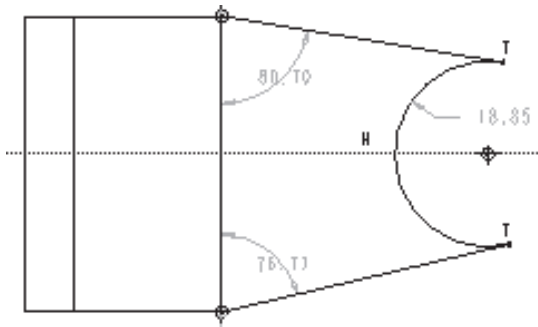

Figure B-4 Sketch after applying constraints

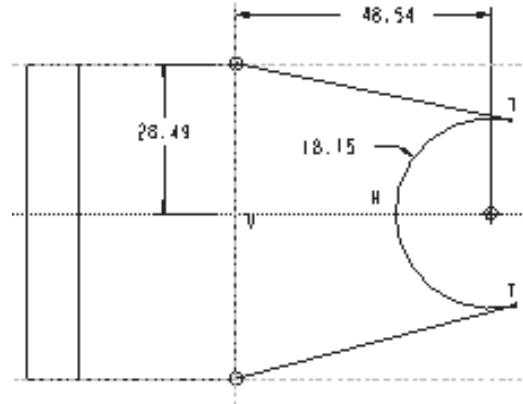

Figure B-5 Sketch after dimensioning

### Modifying the Dimensions

1. Select all the dimensions by using CTRL+ALT+A and choose the **Modify the values of dimensions, geometry of splines, or text entities.** button to display the **Modify Dimensions** dialog box. All the three dimensions are displayed in this dialog box.
2. Clear the **Regenerate** check box and then modify the values of the dimensions.
3. After modifying all the dimensions, choose the **Regenerate the section and close the dialog** button from the **Modify Dimensions** dialog box. The message **Dimension modifications successfully completed.** is displayed in the **Message Area**.

The sketch is completed and is shown in Figure B-6.

4. Choose the **Continue with the current section.** button to exit the sketcher environment.

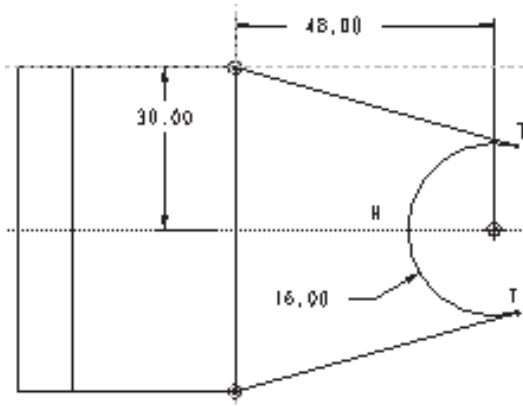

Figure B-6 Sketch after modifying the dimensions

## Chapter 4 > Exercise 2

The following steps explain the procedure to create the sketch of the cut feature created on the right face of the model in Exercise 2 of Chapter 4. The drawing views of the model are shown in Figure 4-96 and the sketch for the cut feature is shown in Figure B-7.

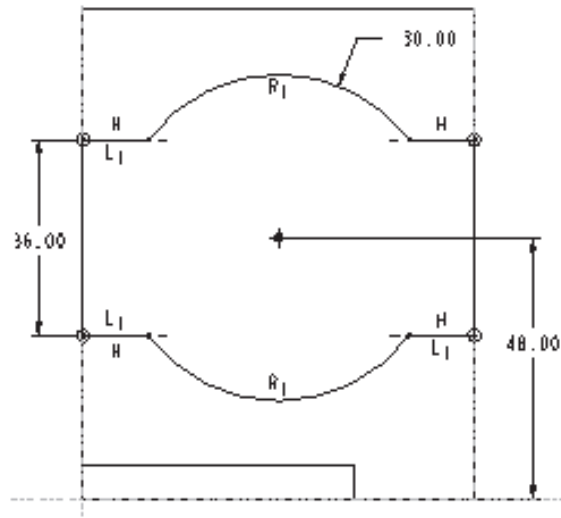

Figure B-7 Sketch for the cut feature

### Creating the Sketch

1. Choose the **Create circle by picking the center and a point on the circle.** button and draw a circle by selecting a center point as shown in Figure B-8.
2. Choose the **Create lines.** button and draw the lines joining the circle as shown in Figure B-9. Choose **Yes** from the **Confirm** dialog box to align the endpoints of lines. As evident from Figure B-9, the lines are automatically aligned to the edge of the existing feature and to the circle. However, you will apply the constraints to the sketch manually.
3. Join the top right horizontal line with the bottom right horizontal line with a vertical line segment. Similarly, join the other two lines on the left.

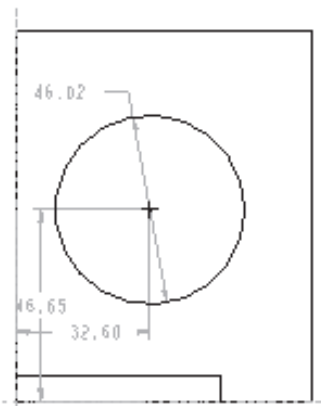

Figure B-8 Sketch of the circle with weak dimensions

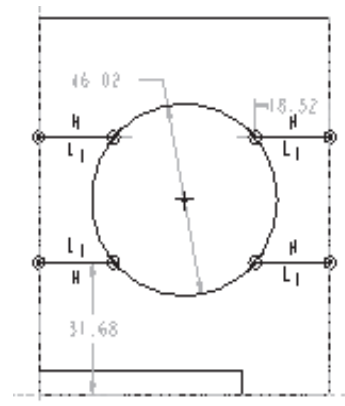

Figure B-9 Sketch of the lines joined to the circle on the circumference with weak dimensions

4. Choose the **Dynamically trim the section entities.** button from the **Right Toolchest** and bring the mouse on the right portion of the circle. You will notice that a part of the circle is highlighted in magenta color.
5. Using the left mouse button, select the part of the circle that has turned to magenta. This portion of the circle gets erased. Similarly, erase the left part of the circle that is not required. The sketch after trimming the circle is shown in Figure B-10.

### Applying Constraints

1. Choose the **Impose sketcher constraints on the section.** button. The **Constraints** dialog box is displayed.
2. Choose the **Create Equal Lengths, Equal Radii, or Same Curvature constraint** button and select the top right line and then the top left line to make them of equal length. Similarly, make the remaining lines of equal length.
3. Select the top arc and the bottom arc to apply the equal radii constraint.
4. Choose the **Make line or two vertices horizontal** button from the **Constraints** dialog box and select the points at the top of the sketch where the lines and the arc meet. The two points are now horizontally aligned. Similarly, horizontally align the two points at the bottom.

The sketch after applying the constraints should be similar to the sketch shown in Figure B-11. If the **Resolve Sketch** dialog box appears, delete the constraints that are not required in the sketch.

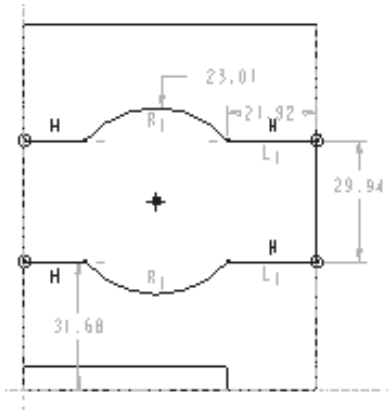

Figure B-10 Sketch after trimming the circle

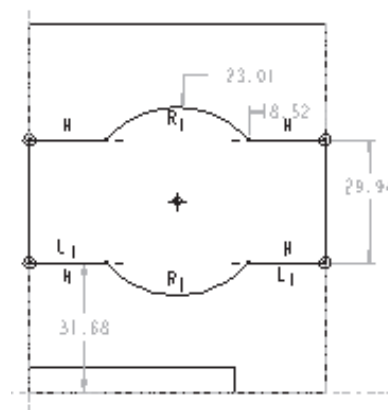

Figure B-11 Sketch after applying constraints

### Applying Dimensions

1. Choose the **Create defining dimension.** button and select the center of the circle and the bottom edge of the existing feature and place the dimension using the middle mouse button as shown in Figure B-12.

The weak dimension is already applied to the circle and therefore, you need not dimension it again.

2. Select the left vertical line in the sketch and place the dimension as shown in Figure B-12.

### Modifying the Dimensions

1. Select all the dimensions by using CTRL+ALT+A and choose the **Modify the values of dimensions, geometry of splines, or text entities.** button to display the **Modify Dimensions** dialog box. All the three dimensions are displayed in this dialog box.
2. Clear the **Regenerate** check box and then modify the values of the dimensions.
3. After modifying all the dimensions, choose the **Regenerate the section and close the dialog** button from the **Modify Dimensions** dialog box. The message **Dimension modifications successfully completed.** is displayed in the **Message Area.**

The sketch is completed and is shown in Figure B-13.

4. Choose the **Continue with the current section.** button to exit the sketcher environment.

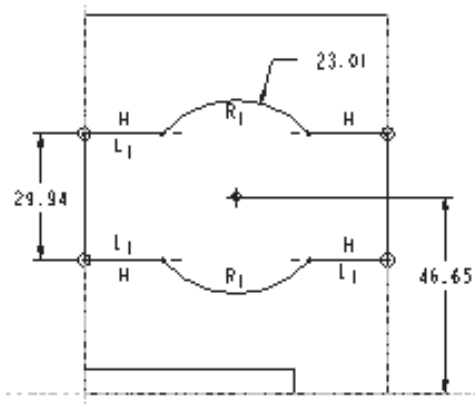

Figure B-12 Sketch after dimensioning

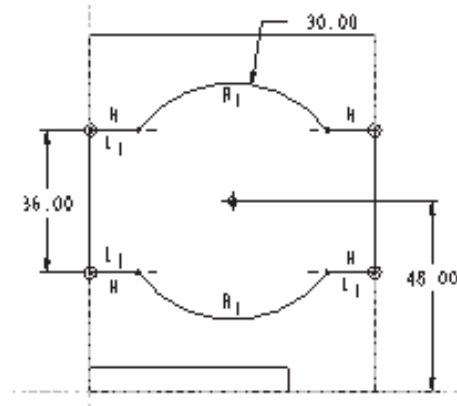

Figure B-13 Sketch after modifying the dimensions

## Chapter 6 > Tutorial 2

The following steps explain the procedure to create the sketch of the seventh feature created on the top face of the base feature in Tutorial 2 of Chapter 6. The sketch in Figure 6-41 is shown in Figure B-14.

### Creating the Sketch

1. Choose the **Create circle by picking the center and a point on the circle.** button and draw a circle such that the center of the circle lies at the intersection point of the **RIGHT** and the **FRONT** datum planes.

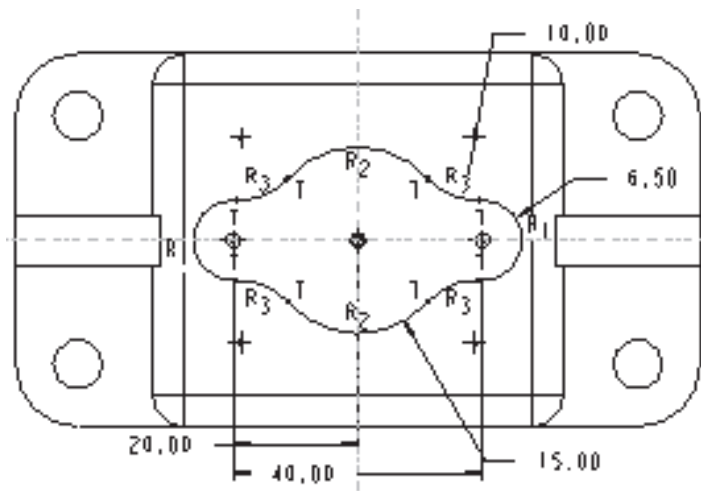

Figure B-14 Sketch of the seventh feature

2. Draw the second circle by specifying the center point on the **FRONT** datum plane.
3. Draw the third circle by specifying the center point on the **FRONT** datum plane and complete the circle when the equal radius constraint appears on the right and the left circles. The equal radius constraint that is applied automatically is a weak constraint and later you will need to apply the equal radii constraint manually.

The sketch after drawing the three circles is shown in Figure B-15.

4. Choose the **Create a circular fillet between two entities**. button and select a point on the top of the right circle and a point on the top of the middle circle. The fillet is created.
5. Similarly, create the remaining fillets. The sketch after creating the fillets is shown in Figure B-16.

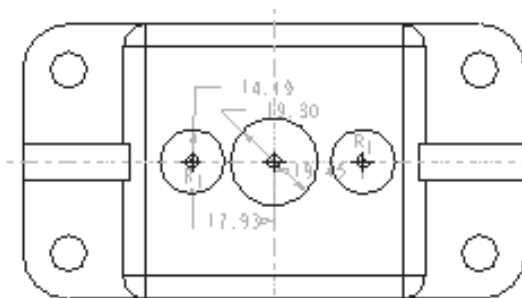

Figure B-15 Three circles drawn

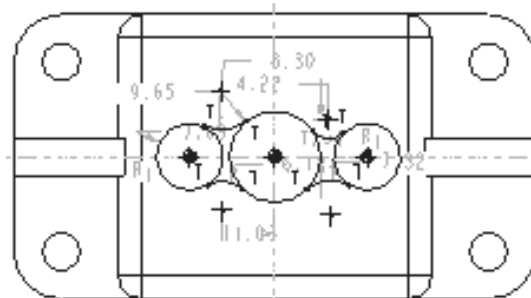

Figure B-16 Fillets created on the circles

6. Choose the **Dynamically trim section entities.** button and delete the part of the circles that is not required. The sketch after trimming the circles is shown in Figure B-17.

### Applying Constraints

1. Choose the **Impose sketcher constraints on the section.** button. The **Constraints** dialog box is displayed.
2. Choose the **Create Equal Lengths, Equal Radii, or Same Curvature constraint** button and apply the equal radii constraint to the arcs as shown in Figure B-18.

The weak dimensions are not shown in Figure B-18 for clarity of the sketch.

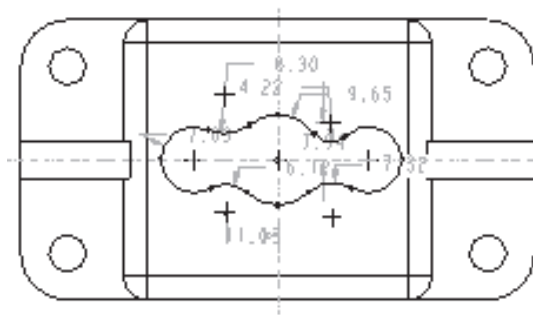

*Figure B-17 Sketch after filleting*

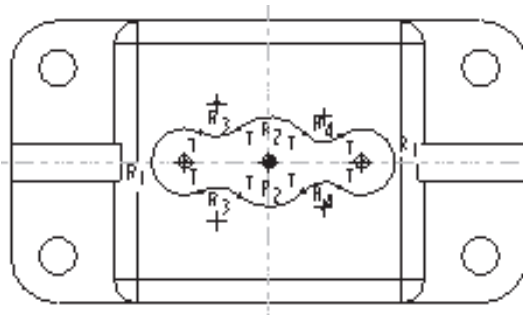

*Figure B-18 Sketch after applying constraints*

### Dimensioning the Sketch

1. Choose the **Create defining dimension.** button and select the centers of the left circle and the right circle and place the dimension using the middle mouse button as shown in Figure B-19.
2. Dimension the remaining entities as shown in Figure B-19.

### Modifying the Dimensions

1. Select all the dimensions by using CTRL+ALT+A and choose the **Modify the values of dimensions, geometry of splines, or text entities.** button to display the **Modify Dimensions** dialog box. All the five dimensions are displayed in this dialog box.
2. Clear the **Regenerate** check box and then modify the values of the dimensions.
3. After modifying all the dimensions, choose the **Regenerate the section and close the dialog** button from the **Modify Dimensions** dialog box. The message **Dimension modifications successfully completed** is displayed in the **Message Area**.

The sketch is completed and is shown in Figure B-20.

4. Choose the **Continue with the current section.** button to exit the sketcher environment.

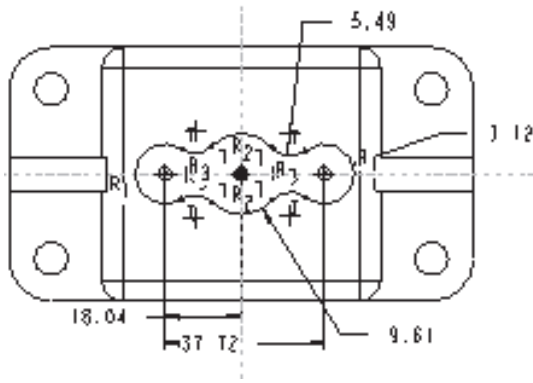

*Figure B-19* Sketch after dimensioning

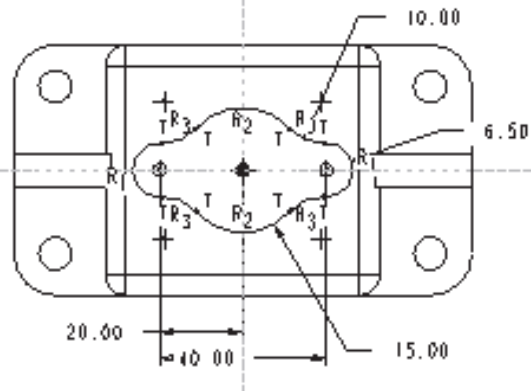

*Figure B-20* Sketch after modifying the dimensions